

SEZIONE / SECTION

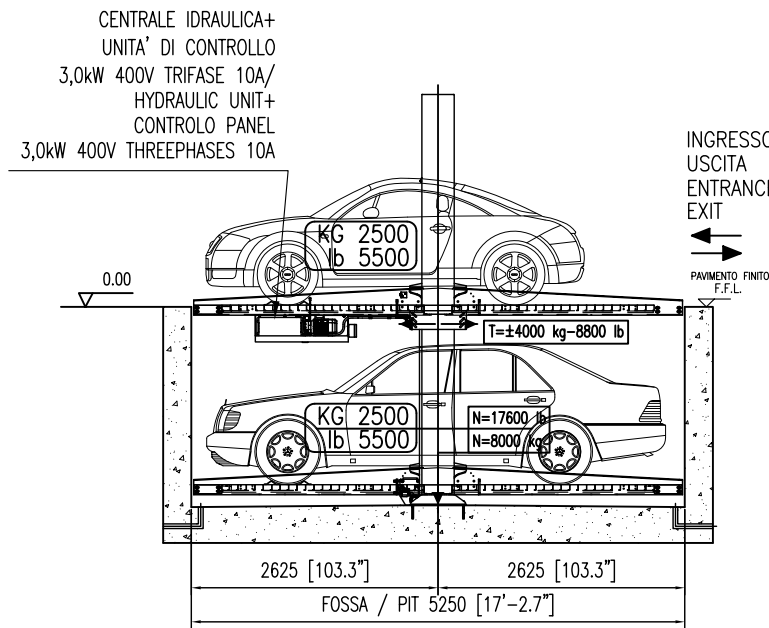

SEZIONE / SECTION

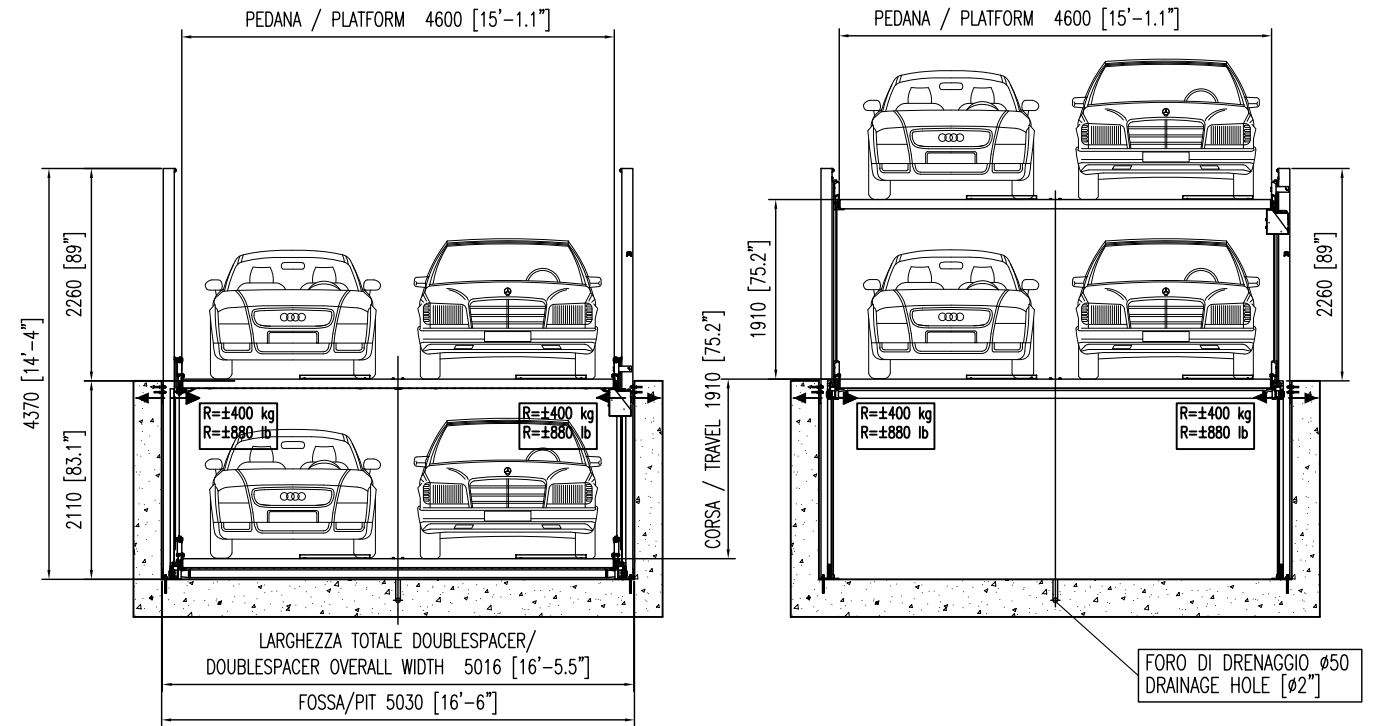
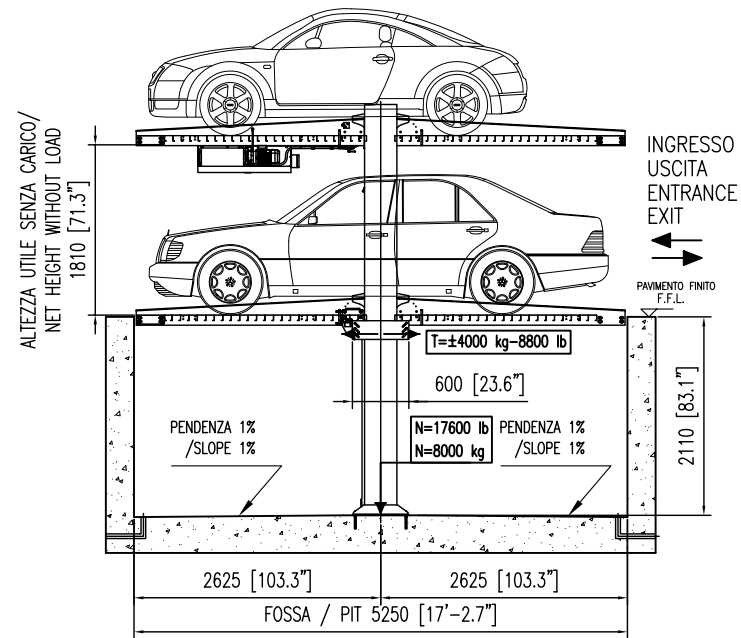

VISTA IN PIANTA / PLANT VIEW

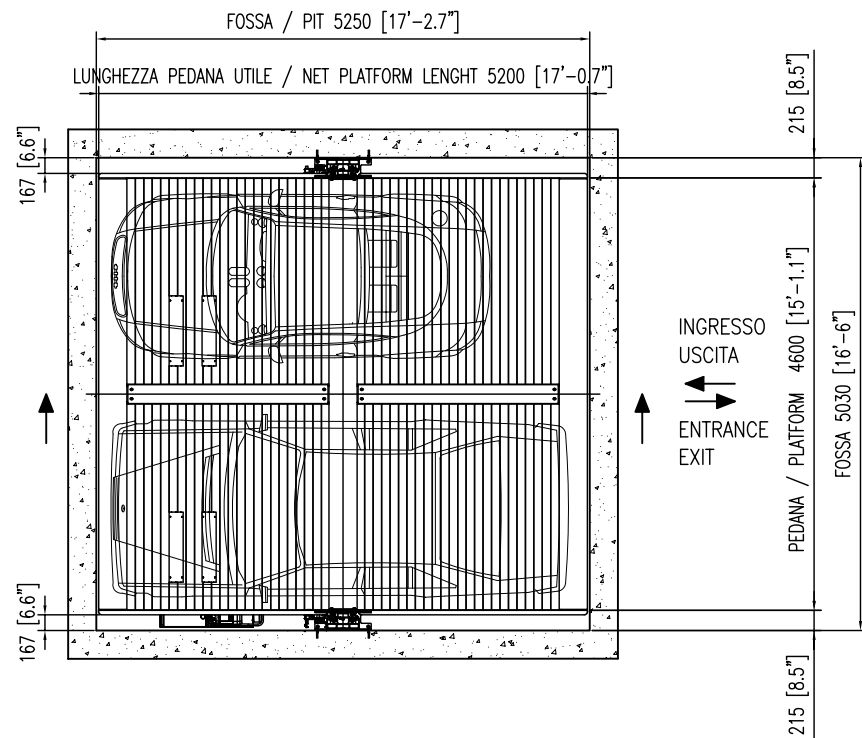

LARGHEZZA PEDANA/ PLATFORM WIDTH		LARGHEZZA FOSSA/ PIT WIDTH	
mm	feet	mm	feet
4600	15'-1.1"	5030	16'-6.0"
4800	15'-9.0"	5230	17'-1.9"
5000	16'-4.8"	5430	17'-9.8"
5200	17'-0.7"	5630	18'-5.7"

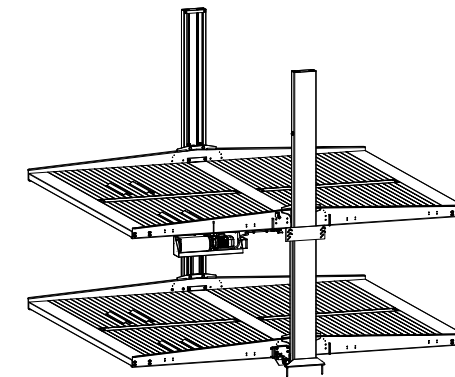

DOUBLE SPACER 25/2 - PLATFORM 4600x5200

4018075002